

APOLLO PRO XL

COMMERCIAL FLUIDROWER

The FDF Apollo Pro XL FluidRower is a performance heavyweight in the commercial rowing market, being visually unique and captivating in its aesthetic design. The highest quality, ethically sourced American Ash wood wraps around a robust sculpted steel frame ensuring product integrity as well as luxurious style.

Defined by its huge Fluid Resistance range provided by our patented Twin Tank [XL] system, this commercial rower will excel under extreme power - bringing a resistance challenge to even the fittest individual.

Bringing 50% greater Fluid Resistance from our patented XL tank, with 10 distinct levels of adjustment, the Apollo Pro XL delivers a true to life stroke with the sensory satisfaction of rowing on water. The range of adjustability from "feather light to Olympic challenge" redefines the opportunities for a work out on a rowing machine.

For such an over performer, this machine boasts a compact footprint and can be stored on end with ease. It's also compatible with FDF's optional Seat Back Kit for extra lumbar support, and the Elevate Kit for easier on-off access.



FLUID ROWER



**HYBRID
AMERICAN ASH
WOOD/STEEL
FRAME**

Industrial nylon belt for smooth and quiet rowing

Sculpted steel frame

Bluetooth monitor

Premium ergonomic contoured handle

Textured seat to prevent slipping

Transport wheels

Height adjustable footplate

Hand-lacquered American Ash woodgrain frame

Seat rail brushes wipe away grit protecting seat rail

Double sealed precision aligned twin fluid resistance tank

View the full range of rowers at [FLUIDROWER.COM](https://www.fluidrower.com)

Visit [FIRSTDEGREEFITNESS.COM](https://www.firstdegreefitness.com) to view all FDF product ranges.

APOLLO PRO XL FLUIDROWER

PRODUCT SPECIFICATIONS

PRODUCT MODEL NO:	APPX
FLUID RESISTANCE:	FDF Horizontal XL Twin Tank - 10 Levels
MONITOR:	FDF  Bluetooth / Heart Rate Compatible
PRODUCT NET WEIGHT:	36.04kg [79.45lb]
PRODUCT GROSS WEIGHT:	44.64kg [98.42lb]
DIMENSIONS:	L 2,130mm [83.85"] x W 540mm [21.25"] x H 560mm [22.05"]
MIN ACTIVE AREA REQUIRED:	L 2,450mm [96.45"] x W 1,150mm [45.27"]
STORED VERTICAL DIMENSIONS:	L 560mm [22.05"] x W 540mm [21.25"] x H 2,130mm [83.85"]
MAX USER WEIGHT:	150kg [330lb]
COMMERCIAL WARRANTY:	Frame 10 years - Fluid Tank 5 years Mechanical and all other non wearing components - 2 years



CONSOLE FEATURES

- +  Bluetooth Connectivity
- + Auto start
- + Time - Elapsed time
- + Level - Auto to selected resistance level
- + 500M Time - Time to row 500 meters
- + Watt - Unit of power per stroke
- + Distance - Updated every second
- + SPM - Strokes per minute
- + Power Graphs - 2 Options
- + Heart rate - Polar compatible
- + Calories burned per hour

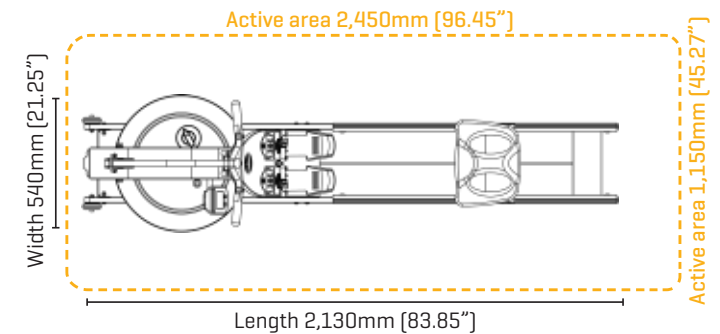

ABOUT FDF (FIRST DEGREE FITNESS)

FDF is the leader in designing and manufacturing a range of adjustable Fluid Resistance fitness machines for commercial and residential applications. At the heart of the fitness range is our unique and patented Twin Tank Fluid Resistance system. The adjustable Fluid Resistance system challenged the conventional thinking of how water could work to provide adjustable resistance rather than just a liquid mass flywheel. The patented Twin Tank system provides silky smooth resistance at any speed and is perfect for cardio training, warm-ups, cool downs, intense HIIT workouts or rehabilitation programs. FDF categorizes the range of adjustable Fluid Resistance machines under the banners, **FluidRower**, **FluidExercise** and **FluidPowerZone**, see the adjacent web links. FDF products are distributed throughout the globe and are popular in Fitness Centers, Hotels and Apartments, Sporting Clubs, Universities, First Responders, Defence Force Training Facilities and Physical Rehabilitation Clinics.

OPTIONAL FLUIDROWER ACCESSORIES



TOUCH HEART RATE HANDLE



PHONE HOLDER



ELEVATE KIT



SEAT BACK KIT



View all FDF products at

FLUIDROWER.com

FLUIDEXERCISE.com

FLUIDPOWERZONE.com

* FDF reserves the right to modify any product design, manufacture or aesthetic without notice or consultation. Product specifications and warranties may vary from country to country.