

## Important Safety Instructions - Before using this equipment, obey the following warnings:

**⚠** This icon means a potentially hazardous situation which, if not avoided, could result in death or serious injury. Read and understand all Warnings on this equipment.

• Children must not be let on or near to this equipment. Moving parts and other features of the equipment can be dangerous to children. • Not intended for use by anyone under 14 years of age. • Not intended for use by persons with medical conditions where those conditions may impact the safe operation of the equipment or pose a risk of injury to the user. • Consult a physician before starting an exercise program. Stop exercising if you feel pain or tightness in your chest, become short of breath, or feel faint. Contact your doctor before using the equipment again. • Examine this equipment for loose parts or signs of wear. Tighten or replace any worn or loose components before use. Examine all fasteners carefully. Contact your local distributor for repair information. • This equipment is for home use only. • Set up and operate stand on a hard, level surface. • Keep at least 1.3 m (50 in) clear on each side of the stand. This is the recommended safe distance for access and passage around the stand. • Keep third parties out of this area when the device is in use. • Do not stand, sit or climb on this device. • Read and understand the complete user guide. Keep manual for future reference. • Read and understand all warnings on this device. If at any time the warning stickers become loose, unreadable or dislodged, contact your local distributor for replacement stickers. • Children must not be allowed on or near to this device. •

## SAVE THESE INSTRUCTIONS.

Nautilus, Inc., 5415 Centerpoint Parkway, Groveport, OH 43125 USA, www.NautilusInc.com - Customer Service: North America (800) 605-3369, csnls@nautilus.com | Nautilus (Shanghai) Fitness Equipments Co, Ltd, Room 1701 & 1702, 1018 Changning Road, Changning District, Shanghai, China 200042, www.nautilus.cn - 86 21 6115 9668 | outside U.S. www.nautilusinternational.com | Printed in China | © 2018 Nautilus, Inc. | Bowflex, the B logo, and SelectTech are trademarks owned by or licensed to Nautilus, Inc., which are registered or otherwise protected by common law in the United States and other countries. | ORIGINAL DOCUMENT - ENGLISH VERSION ONLY

### Specifications

**Stand Weight:** approx. 29.3 lb / 13.29 kg

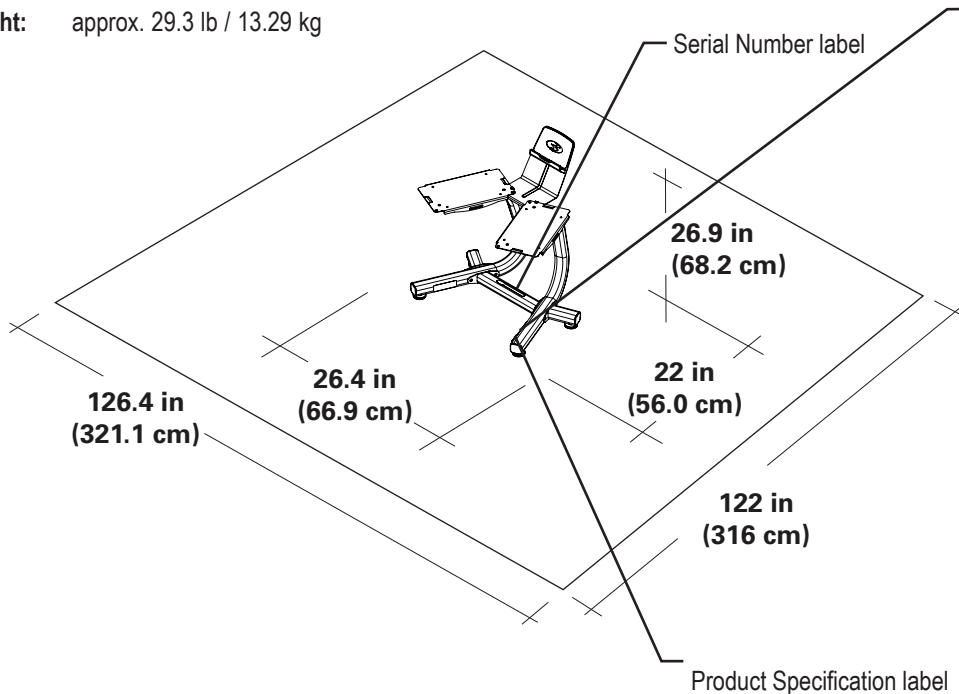

### ⚠ WARNING!

- Read and understand the complete user guide. Keep manual for future reference.
- Read and understand all warnings on this device. If at any time the warning stickers become loose, unreadable or dislodged, contact Nautilus Customer Service for replacement stickers.
- Children must not be allowed on or near to this device.
- This device is for home use only.
- Set up and operate this device on a solid, level, horizontal surface.
- Make sure that you give users enough free space around the device for safe operation. (See product specifications for free space dimensions).
- Keep third parties out of this area when the device is in use.
- Do not stand, sit or climb on this device.
- Consult a physician prior to using any exercise equipment.

### Maintenance

**⚠** The safety and performance of this product can be maintained only if it is examined regularly for damage and wear.

Examine the equipment before each use for damage and wear. Replace broken components immediately or put the equipment out of use until repaired.

**Daily/Before Each Use:** Examine equipment. Make sure it looks in good condition and operates smoothly. If you find damage, DO NOT USE. Contact Customer Service for servicing.

**Daily/After Each Use:** Clean equipment with a clean, dry cloth. Do not use cleansers containing enzymes.

**Weekly:** Clean equipment fully with a clean cloth and ammonia-based cleaner. Touch up any scratches with touch-up paint to prevent rust, if necessary.

**Monthly:** Examine the frame for signs of cracking or permanent bending. Do not use the equipment if you see these signs. Contact Customer Service immediately.

If you have any questions on the correct use or maintenance of this equipment, contact Customer Service at 1 (800) 605-3369. Only Nautilus-trained or Nautilus-authorized personnel should make extensions, readjustments, modifications, or repairs.

## 552 Dumbbell

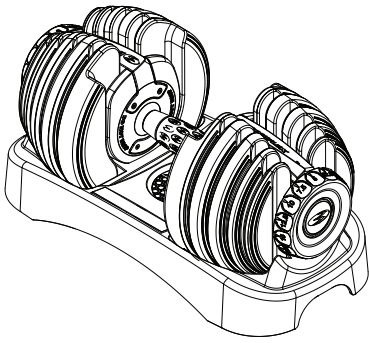

## 560 Dumbbell

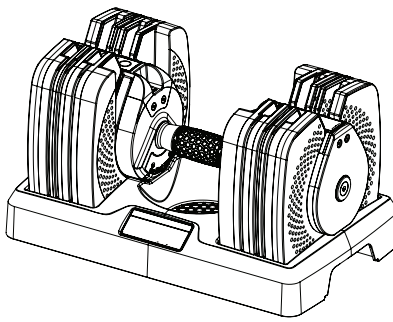

## 1090 Dumbbell

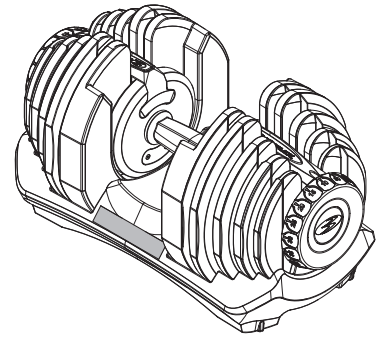

( Note: Go to page 5 for the 560 Dumbbells. )

### Tools (included)



3mm  
6mm



#2



Item	Qty	Description
1	1	Bottom Cross Brace
2	1	Stand Leg, Left
3	1	Stand Leg, Right
4	2	Rear Stabilizer
5	2	Dumbbell Platform
6	1	Media Tray
7	2	Retaining Strap
8	4	Leveler

### Large Hardware Card

Item	Qty	Description
A	4	Bumpers (for 552 or 1090 dumbbell)
B	8	Pan Phillips Screw, M3.5x9.5
C	8	Button Head Cap Screw, M10x1.5x70
D	8	Securing Nut, M10
E	16	Flat Washer, M10
F	4	Flat Washer, M5
G	4	Flat Head Cap Screw, M5x0.8x12
H	4	Securing Nut, M5

### Small Hardware Card (for 560 Dumbbells only)

J	8	Bumpers (for 560 dumbbell)
K	8	Pan Phillips Screw, M6x16

**Note:** Selected pieces of Hardware have been provided as spares on the Hardware Card. Be aware that there may be remaining Hardware after the proper assembly of the equipment.

## ( for the 552 or 1090 Dumbbells )

### 1. Attach the Appropriate Bumpers for Your 552 or 1090 Dumbbells

**Note:** Go to page 5 for the 560 Dumbbells.

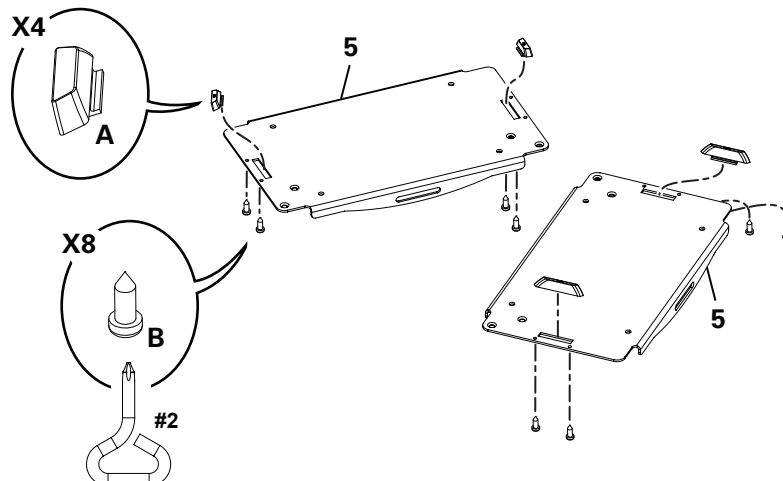

## 2. Assemble the Stand

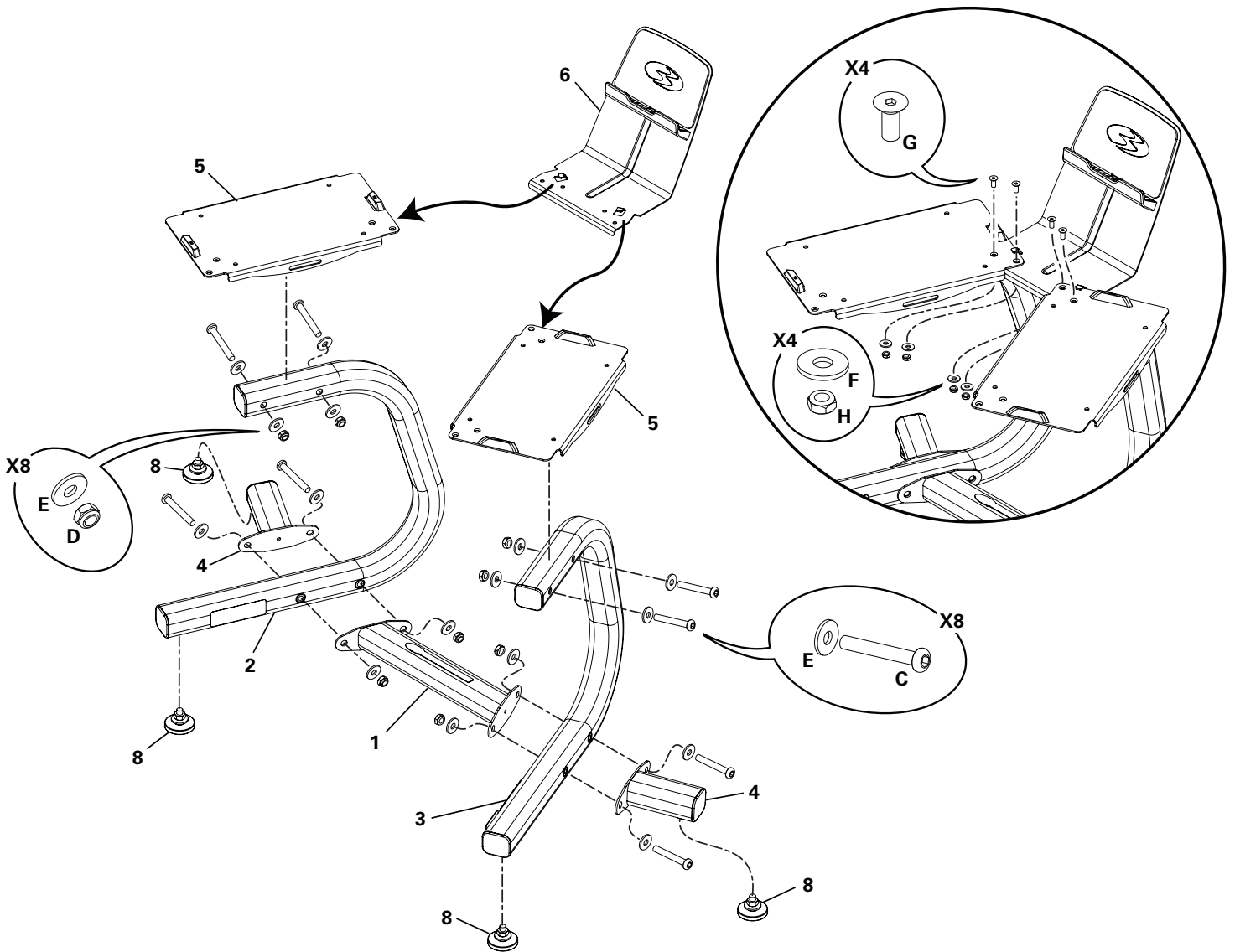

### 3. Attach the Retaining Straps to the Stand and Fully Secure each Dumbbell Base

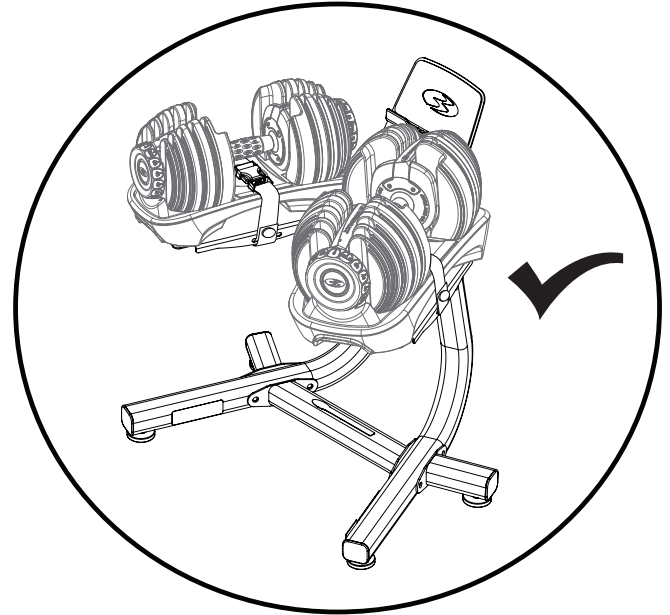
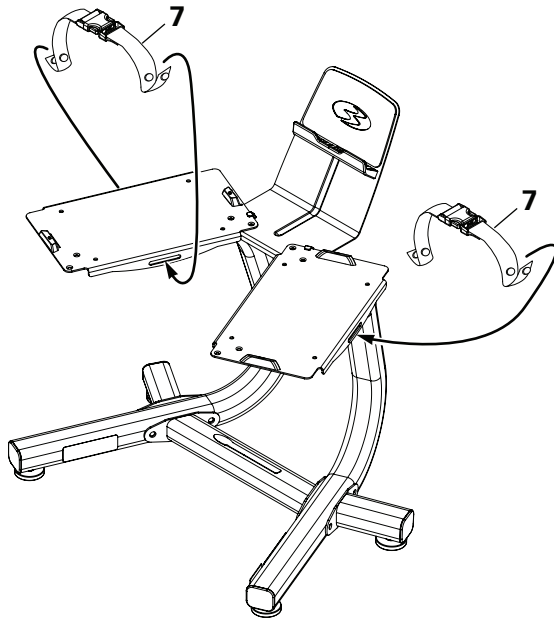

### 4. Final Inspection

Inspect your equipment to ensure that all fasteners are tight and components are properly assembled.

**⚠** Do not use or put the equipment into service until the equipment has been fully assembled and inspected for correct performance in accordance with the User's Guide. Fully tighten the hardware before you put the dumbbells into the installed dumbbell platforms or bases on the stand.

To validate warranty support, keep the original proof of purchase and record the following information:

**Serial Number** \_\_\_\_\_ **Date of Purchase** \_\_\_\_\_

To register your product warranty, go to: [www.bowflex.com/register](http://www.bowflex.com/register) or call 1 (800) 605-3369.

If you have questions or problems with your product, please call 1 (800) 605-3369, or go to: [www.bowflex.com](http://www.bowflex.com).

# ( for the 560 Dumbbell )

## 1. Assemble the Stand

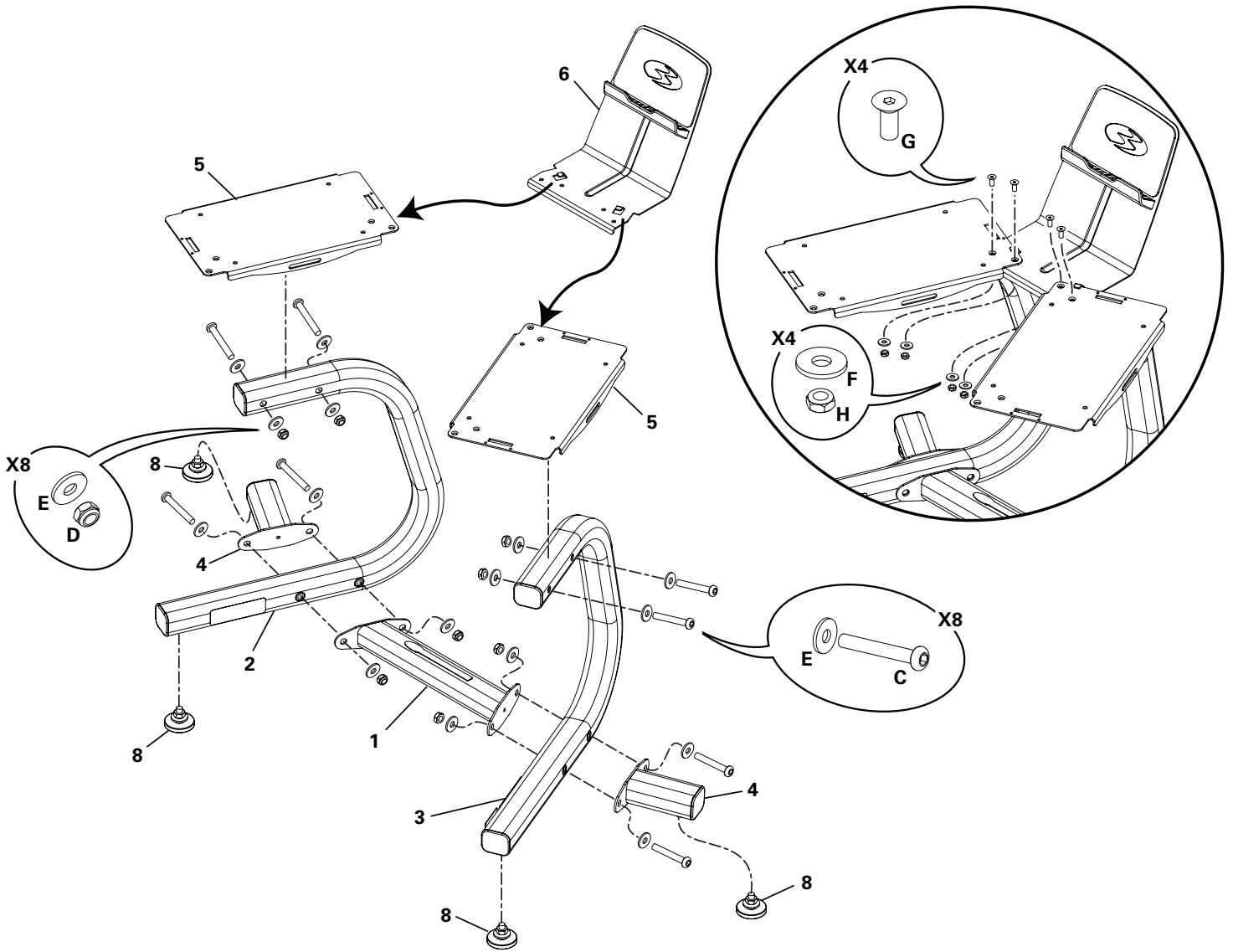

## 2. Remove and Discard the Rubber Stabilizers, and then Attach the Dumbbell Bases

- ⚠ Remove the dumbbell from its base before you attach the Dumbbell Base to the stand to make sure that the dumbbell does not fall during installation.  
Fully tighten the hardware before you put the dumbbells into the installed Dumbbell Bases on the stand.

**Note:** The Rubber Stabilizers and hardware must be removed from the Dumbbell Bases and discarded. The 560 Dumbbell Base is not included with the Stand.

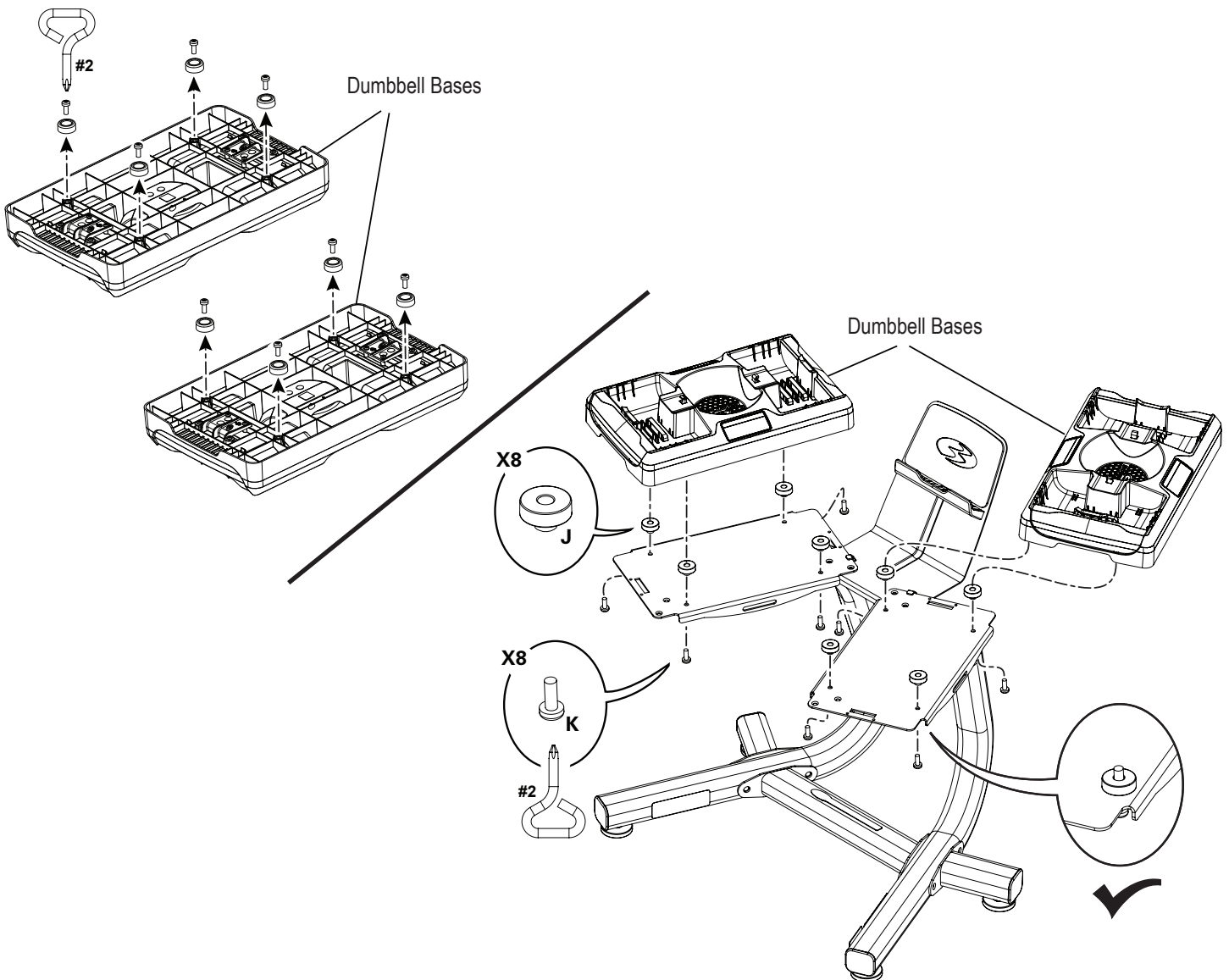

### 3. Final Inspection

Inspect your equipment to ensure that all fasteners are tight and components are properly assembled.

**⚠ Do not use or put the equipment into service until the equipment has been fully assembled and inspected for correct performance in accordance with the User's Guide. Fully tighten the hardware before you put the dumbbells into the installed dumbbell platforms or bases on the stand.**

To validate warranty support, keep the original proof of purchase and record the following information:

**Serial Number** \_\_\_\_\_ **Date of Purchase** \_\_\_\_\_

To register your product warranty, go to: [www.bowflex.com/register](http://www.bowflex.com/register) or call 1 (800) 605-3369.

If you have questions or problems with your product, please call 1 (800) 605-3369, or go to: [www.bowflex.com](http://www.bowflex.com).

## Warranty

### Who Is Covered

This warranty is valid only to the original purchaser and is not transferable or applicable to any other person(s).

### What Is Covered

Nautilus, Inc. warrants that this product is free from defects in materials and workmanship, when used for the purpose intended, under normal conditions, and provided it receives proper care and maintenance as described in the Product's Assembly and Owner's manual. This warranty is good only for authentic, original, legitimate machines manufactured by Nautilus, Inc. and sold through an authorized agent and used in the United States or Canada.

### Terms

- Frame 10 years
- Media rack 1 year
- Wear parts 30 days

### How Nautilus Will Support the Warranty

Throughout the terms of the warranty coverage, Nautilus, Inc. will repair any machine that proves to be defective in materials or workmanship. Nautilus reserves the right to replace the product in the event a repair is not possible. When Nautilus determines replacement is the correct remedy, Nautilus may apply a limited credit reimbursement toward another Nautilus, Inc. brand Product, at our discretion. This reimbursement may be prorated based on length of ownership. Nautilus, Inc. is not responsible for dealer labor or maintenance charges beyond the applicable warranty period(s) stated herein. Nautilus, Inc. reserves the right to substitute material, parts or products of equal or better quality if identical materials or products are not available at the time of service under this warranty. Any replacement of the product under the terms of the Warranty in no way extends the original Warranty period. Any limited credit reimbursement may be prorated based on length of ownership. THESE REMEDIES ARE THE EXCLUSIVE AND SOLE REMEDIES FOR ANY BREACH OF WARRANTY.

### What You Must Do

- Retain appropriate and acceptable Proof of Purchase.
- Operate, maintain, and inspect the product as specified in the Product Documentation (Assembly, Owner's Manuals, etc.).
- Product must be used exclusively for the purpose intended.
- Notify Nautilus within 30 days after detecting an issue with the product.
- Install replacement parts or components in accordance with any Nautilus instructions.
- Perform diagnostic procedures with a trained Nautilus, Inc representative if requested.
- This warranty does not cover in home repair costs (labor, etc) or related charges.

### What Is Not Covered

- Damage due to abuse, tampering or modification of the Product, failure to properly follow assembly instructions, maintenance instructions, or safety warnings as stated in the Product Documentation (Assembly, Owner's Manuals, etc), damage due to improper storage or the effect of environmental conditions such as moisture or weather, misuse, mishandling, accident, natural disasters, power surges.
- A machine placed or used in a commercial or institutional setting. This includes gyms, corporations, work places, clubs, fitness centers and any public or private entity that has a machine for use by its members, customers, employees or affiliates.
- Damage caused by exceeding maximum user weights as defined in Products Owner's Manual or on the warning label.
- Damage due to normal usage and wear and tear.
- This warranty does not extend to any territories or countries outside the United States and Canada.

### How to Obtain Warranty Support

For Products purchased directly from Nautilus, Inc. contact the Nautilus office listed on the Contacts page of the Product's Owner's manual. You may be required to return the defective component to a specified address for repair or inspection, at your expense. Standard ground shipping of any warranty replacement parts will be paid by Nautilus, Inc. For products purchased from a retail outlet, you may be asked to contact your retailer for warranty support.

### Exclusions

The preceding warranties are the sole and exclusive express warranties made by Nautilus, Inc. They supersede any prior, contrary or additional representations, whether oral or written. No agent, representative, dealer, person or employee has the authority to alter or increase the obligations or limitations of this warranty. Any implied warranties, including the WARRANTY OF MERCHANTABILITY and any WARRANTY OF FITNESS FOR A PARTICULAR PURPOSE, are limited in duration to the term of the applicable express warranty provided above, whichever is longer. Some states do not allow limitations on how long an implied warranty lasts, so the above limitation may not apply to you.

### Limitation of Remedies

EXCEPT AS OTHERWISE REQUIRED BY APPLICABLE LAW, THE PURCHASER'S EXCLUSIVE REMEDY IS LIMITED TO REPAIR OR REPLACEMENT OF ANY COMPONENT DEEMED BY NAUTILUS, INC. TO BE DEFECTIVE UNDER THE TERMS AND CONDITIONS STATED HEREIN. IN NO EVENT WILL NAUTILUS, INC. BE LIABLE FOR ANY SPECIAL, CONSEQUENTIAL, INCIDENTAL, INDIRECT OR ECONOMIC DAMAGES, REGARDLESS OF THE THEORY OF LIABILITY (INCLUDING, WITHOUT LIMITATION, PRODUCT LIABILITY, NEGLIGENCE OR OTHER TORT) OR FOR ANY LOST REVENUE, PROFIT, DATA, PRIVACY OR FOR ANY PUNITIVE DAMAGES ARISING OUT OF OR RELATED TO THE USE OF THE FITNESS MACHINE EVEN IF NAUTILUS, INC. HAS BEEN ADVISED OF THE POSSIBILITY OF SUCH DAMAGES. THIS EXCLUSION AND LIMITATION SHALL APPLY EVEN IF ANY REMEDY FAILS OF ITS ESSENTIAL PURPOSE. SOME STATES DO NOT ALLOW THE EXCLUSION OR LIMITATION OF CONSEQUENTIAL OR INCIDENTAL TYPE DAMAGES SO THE ABOVE LIMITATION MAY NOT APPLY TO YOU.

### State Laws

This warranty gives you specific legal rights. You may also have other rights, which vary from state to state.

### Expirations

If the warranty has expired, Nautilus, Inc. may assist with replacements or repairs to parts and labor, but there will be a charge for these services. Contact a Nautilus office for information on post-warranty parts and services. Nautilus does not guarantee availability of spare parts after expiration of warranty period.

### International Purchases

If you purchased your machine outside of the United States consult your local distributor or dealer for warranty coverage.

